

# CLEARANCE SURVEYS

Provides critical information to operators and vehicle suppliers

Railroad vehicle suppliers preparing a vehicle dynamic clearance envelope for the design of new equipment, transit agencies preparing for capital upgrades, and commuter railroads trying to evaluate their systems can all benefit greatly from a clearance survey that can provide a complete picture of critical locations within a system.

ENSCO, an industry leader in track inspection surveys for more than 30 years, can provide the vital information related to clearances existing on railroads through our clearance survey services.

We combine our railroad survey experience with the latest in survey-related technology to provide clearance data collected in the most efficient manner possible. ENSCO uses proven laser-based survey equipment, and can mount the survey equipment on a variety of rail-based vehicles to accommodate any number of special survey requirements, such as the collection of data in areas where track geometry or other system features prevent the use of traditional high rail vehicles.

ENSCO can collect clearance data at virtually any interval of interest, often increasing the measurement frequency in areas of particular interest, such as station platforms, yard track or any other area of special concern.

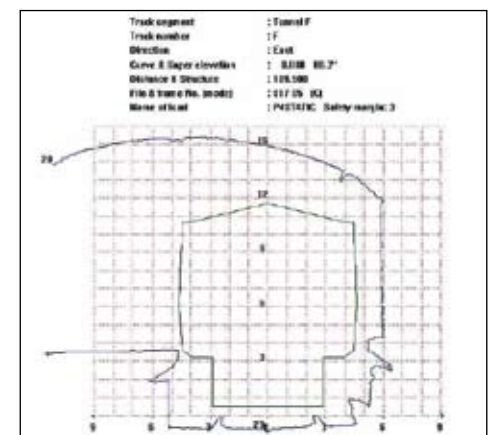
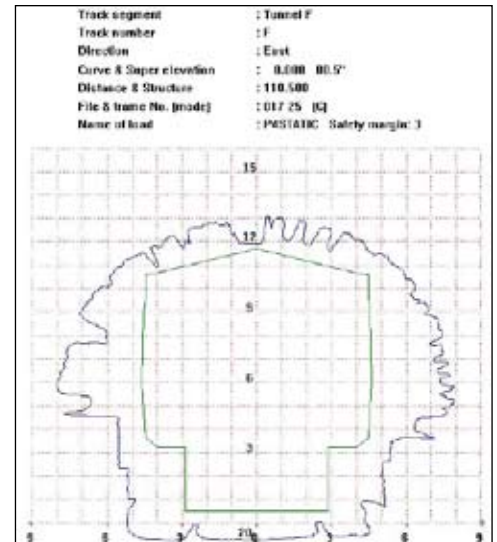
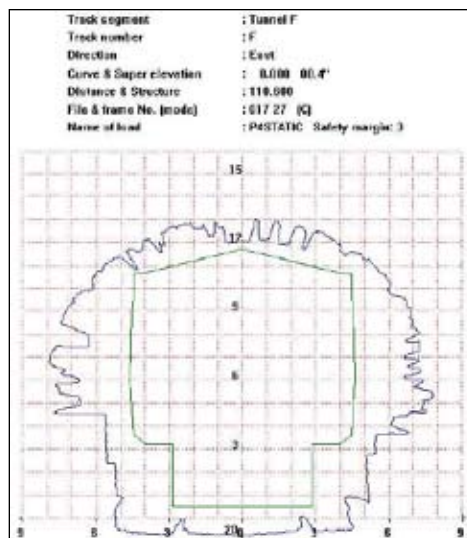

For more information,  
please contact:  
ENSCO, Inc.  
703-321-4400  
rail@ensco.com  
www.ensco.com/rail

05.0157



Innovation Starts Here

5400 Port Royal Road  
Springfield, VA 22151  
703-321-9000 • 800-ENSCO-VA  
info@ensco.com • www.ensco.com